

I/O Modules, IP20



Type ME44 can be combined with...



Type ME43
Fieldbus Gateway



Type 8741
MFC/MFM

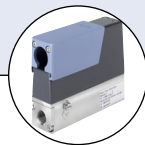

Type 8742
MFC/MFM

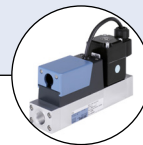

Type 8746
MFC/MFM

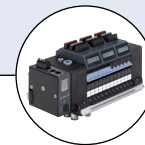

Type 8652
Valve island AirLINE

- I/O modules with configuration possibilities for a diverse range of applications
- Integrated diagnosis possibilities like wire break, short circuit
- Assembly and disassembly possible completely without tools
- Color coded connectors reduce the risk of error during wiring
- Removable terminal block with PUSH-IN spring connection

The fieldbus gateway (ME43) is the central control unit and can be expanded with Bürkert I/O modules of Type ME44 to integrate sensors, actuators or valves via standard signals like 4-20 mA, 0-10 V etc. The 8-channel digital input (8DI) module can be used for 2-wire sensors as well as mechanical switches. The module also has 4 channels which can be configured as frequency inputs. The innovative 6-channel module combines 3 analog inputs and 3 digital outputs in one module (3AI-3DO). With the programmable fieldbus gateway and the 3AI-3DO module control functions can be implemented with utmost ease.

Device properties	Value
Housing material	Polycarbonate
Ambient temperature	-20 ... +60 °C
Dimensions	see diagrams on page 3
Status indicator	RGB LED based on NAMUR NE107, status LEDs per channel
Wire connection cross-section	0.20-1.5 mm ²

Ambient conditions	Value
Altitude above sea level (environment)	max. 2000 m
Storage temperature	-30 ... +80 °C
Ambient temperature	-20 °C ... +60 °C

Electrical specifications	Value	
Operating voltage	24 V DC ±10% via the backplane BPX3	
Power input (Max.)	3AI – 3DO	<3 W If the I/Os are supplied via bÜS, the total current is internally limited to 2 A
	8DI Module	<2 W
Protection class	IP20 according to EN 60529 / IEC 60529	

3AI-3DO Module: Analog input (AI)	
Electrical version	Current input or voltage input
Operating mode	0...20 mA 4...20 mA 0...10 V 0...5 V 0...2 V
Accuracy	0.1 % at 25 °C Temperature coefficient: Current input: ±15 ppm/K Voltage input: ±20 ppm/K
Input impedance	Current measurement at 25 °C ≤100 Ohm Voltage measurement at 25 °C ≥120 kOhm
Galvanic separation	Yes, to the system bus and system voltage
Configurable input (AI as DI)	AI can also be used as DI (configuration via Software Tool - Communicator)
Diagnosis	Detection of error states (at 3.5 mA and 22 mA according to NAMUR NE43) Open loop detection (only for voltage input)
3AI-3DO Module: Digital output (DO: NPN output / N-switching)	
Electrical version	Transistor output
Operating mode	On-Off Threshold PWM (Pulse Width Modulation) PFM (Pulse Frequency Modulation)
Output current	Max. 750 mA per channel Max. 2 A per module (supplied via the backplane)
Diagnosis	Short circuit detection (channel wise only with external power supply)
8-DI Module (Sinking digital input) – suitable for 2-wire sensors and mechanical limit switches	
Electrical version	24 V DC ±10 %
Switching threshold	$V_{OFF} = 0 \dots 5 \text{ V}$ $V_{ON} = 10 \dots 26.4 \text{ V}$
Input current for V_{ON} , type. 24 V DC	max. 6.8 mA
Number of frequency inputs	4 (channel 1, 2, 5, 6)
Frequency input	Max. to 2.5 kHz
Diagnosis	Open-loop detection for 2-wire sensors

Materials

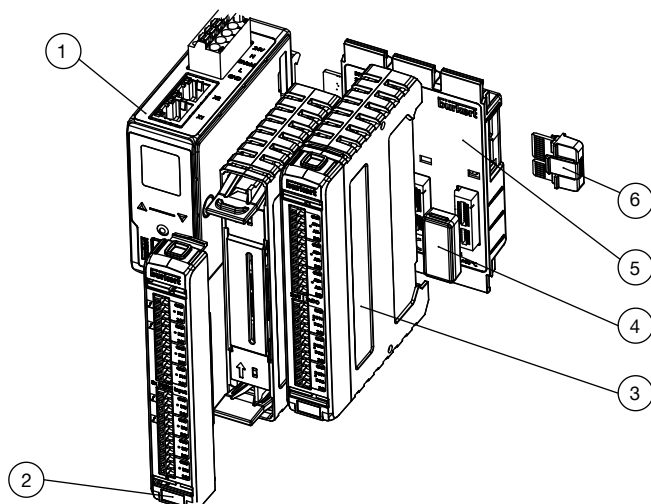

Nr.	Element	Material
1	ME43	Fieldbus gateway
2	ME44	Terminal with PUSH-IN spring connection
3	ME44	I/O module
4	BPX3	Cover module slot
5	BPX3	Backplane (3-fold)
6	ME43	Terminationresistor

Device / process connection

Electrical layout and wiring diagram 3AI-3DO module

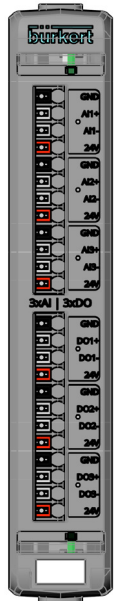

Pin assignment of analog inputs		External wiring
	GND	Ground
	AI1- ... AI3-	Analog input -
	AI1+ ... AI3+	Analog input +
	24 V	Supply voltage 24 V $\pm 10\%$
Pin assignment digital outputs		External wiring
	GND	Ground
	DO1- ... DO3-	Digital output -, GND reference
	DO1+ ... DO3+	Digital output +
	24 V	Supply voltage 24 V $\pm 10\%$

Wiring diagram:

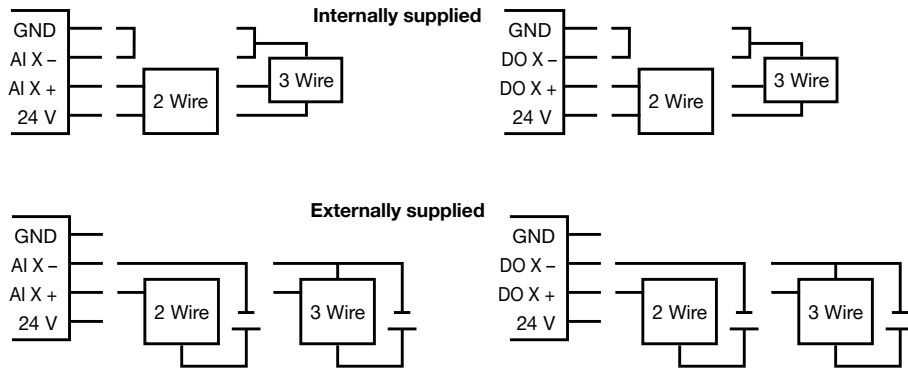

Electrical layout and wiring diagram for 8DI module

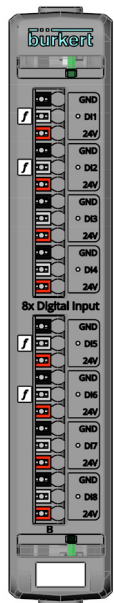

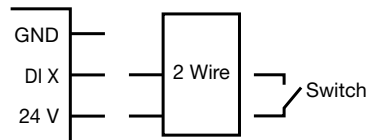

Pin assignment		External wiring
	GND	Ground
	DI1...DI8	Digital input
	24 V	Supply voltage 24 V $\pm 10\%$

Wiring diagram:























Ordering information

Ordering chart

Description	Article no.
3x Analog inputs – 3x Digital outputs 3AI-3DO Module (ME44)	307512 
8x Digital inputs 8DI Module (ME44)	307511 
Backplane 3-fold (BPX3)	307510 

Ordering chart accessories

Description	Article no.
büS cable extension M12 0.1 m	772492 
büS cable extension M12 0.2 m	772402 
büS cable extension M12 0.5 m	772403 
büS cable extension M12 1 m	772404 
büS cable extension M12 3 m	772405 
Socket M12 straight (A coded) ¹⁾	772416 
Connector M12 straight (A coded) ¹⁾	772417 
Socket M12 angled (A coded) ¹⁾	772418 
Connector M12 angled (A coded) ¹⁾	772419 
Y distributor	772420 
Y distributor for networking two separately supplied segments of a büS network	772421 
Terminating resistor (direct pluggable)	303833 
Terminating resistor 120 Ohm plug M12	772424 
Terminating resistor 120 Ohm socket M12	772425 
Power supply unit Type 1573 for top-hat rail, 100-240 V AC / 24 V DC, 1.25 A, NEC Class 2 (UL 1310)	772438 
Power supply unit Type 1573 for top-hat rail, 100-240 V AC / 24 V DC, 1 A, NEC Class 2 (UL 1310)	772361 
Power supply unit Type 1573 for top-hat rail, 100-240 V AC / 24 V DC, 2 A, NEC Class 2 (UL 1310)	772362 
Power supply unit Type 1573 for top-hat rail, 100-240 V AC / 24 V DC, 4 A	772363 
Micro SD card	on request
büS-Stick Set 1 (incl. cable (M12), stick with integrated terminating resistor, power supply and software)	772426 
büS-Stick Set 2 (incl. cable (M12)), stick with integrated terminating resistor	772551 
Software Bürkert Communicator	https://www.burkert.com/en/type/8920

¹⁾ For space reasons, M12 single connectors may not be suitable for simultaneous use on the same side of a Y-distributor. In this case, please use a commercially available overmolded cable.

To find your nearest Bürkert facility, click on the orange box → www.burkert.com